

Some slabs may be differences in the thickness. If there are differences in the thickness is recommended for the following installation.

Thickness tolerance of Radianz[®]

| Thickness | Tolerance |
|-----------|-----------------|
| 20mm | 19.0mm ~ 21.0mm |
| 30mm | 29.0mm ~ 31.0mm |

Adjust the thickness of slabs

- ① Adjust the surface of 2 pieces are perfectly flat.
- ② Grind the bottom side to make even level.

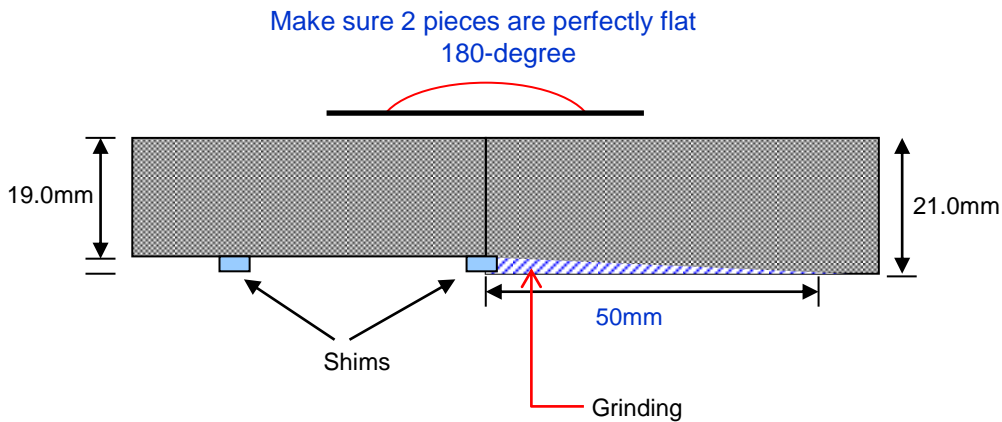

This Technical Bulletin is intended to provide guidelines for optimal fabrication, installation, and performance of Samsung products mentioned. Though the information contained herein is deemed reliable, none of the contents--including but not limited to the instructions, techniques, graphics, and recommendations--is to be understood as implying legal liability of fitness for a specific purpose, any other type of warranty, or being complete or absolute in its range and nature of information.

Depending on the user's particular application, all necessary measures must be taken to verify and test the adequacy for such needs or application. Any information or recommendation herein is strictly for purposes of reference and as such, Samsung SDI assumes no responsibility for its suitability or accuracy or the use of such information for products other than Samsung Staron[®] solid surfaces & Radianz[®] quartz surfaces.

Seaming adhesive procedure

- ① Put a painter's tape across a line where the seam is going to be.

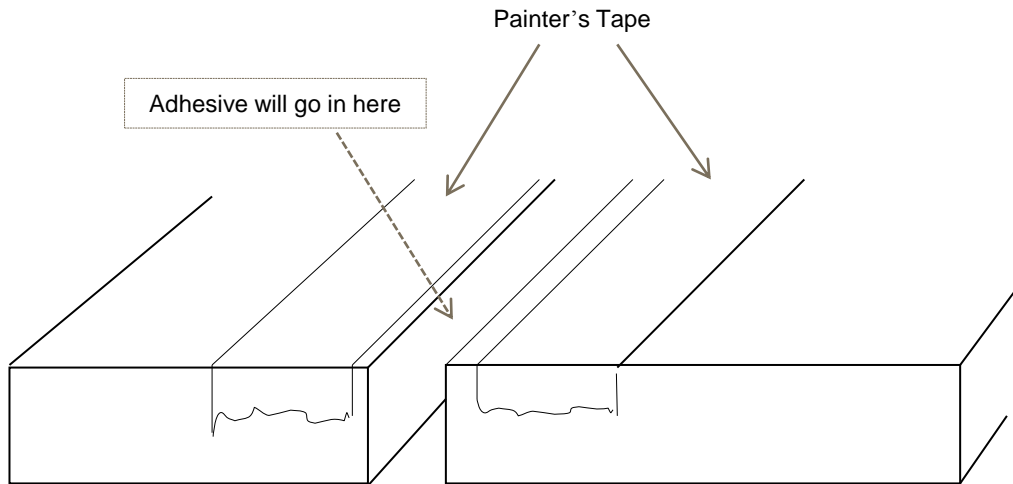

- ② Wipe the edges of 2 seam pieces down with acetone or denatured alcohol.
- ③ Once you wiped the material down, do not touch the pieces. The seam adhesive could pick up oils from your skin and discolor the seam and weaken the seam performance. This is common with light colored materials.
- ④ Put painter's tape on both sides of the slab pieces where seams going to be placed. You can easily remove adhesive residues by doing this.
- ⑤ Decide what kind of clamping method you will use to clamp the two pieces. There are different ways to clamp the pieces together such as:
 - Suction cups and clamps
 - Gorilla grip or similar clamping system (Best choice!)
- ⑥ Once you decided on a clamping method, seam adhesives can be applied.

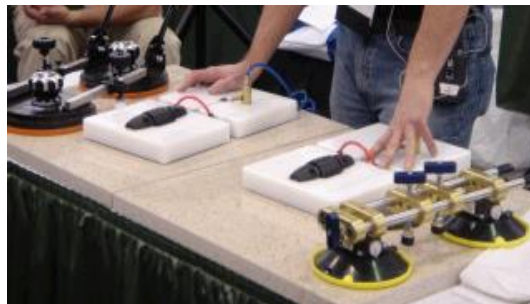

This Technical Bulletin is intended to provide guidelines for optimal fabrication, installation, and performance of Samsung products mentioned. Though the information contained herein is deemed reliable, none of the contents--including but not limited to the instructions, techniques, graphics, and recommendations--is to be understood as implying legal liability of fitness for a specific purpose, any other type of warranty, or being complete or absolute in its range and nature of information.

Depending on the user's particular application, all necessary measures must be taken to verify and test the adequacy for such needs or application. Any information or recommendation herein is strictly for purposes of reference and as such, Samsung SDI assumes no responsibility for its suitability or accuracy or the use of such information for products other than Samsung Staron® solid surfaces & Radianz® quartz surfaces.